

# METLOK<sup>®</sup> HP

## DESIGN & INSTALLATION GUIDE

HIGH  
PERFORMANCE  
SPEEDIER  
INSTALL

CONCEALED FIX ROOF SYSTEM



A Met-TECH<sup>™</sup> GUIDE

AUGUST 2024



**Metroll<sup>®</sup>**

BETTER SERVICE • BETTER BUILDING SOLUTIONS

# METLOK® HP



OPTIMISED UNDERCLIP

Cover: 695mm Height: 40mm

## FEATURES & BENEFITS

- Optimised underclip for speedy installation
- Concealed fix
- Ideal for long runs
- Low pitch

Metlok® HP (High Performance) is a concealed fix roof system designed for long run roofing applications. It can also be used for walling.

Whilst similar to Metlok 700®, Metlok® HP features an underclip, not an overclip. The Metlok® HP underclip does not require installation over the top of the sheets which allows for bulk clip installation to the purlins. This makes Metlok® HP installation speedier and easier.

Metlok® HP is manufactured in a continuous roll from method from 0.42mm and 0.48mm BMT COLORBOND® and ZINCALUME® steels. Metlok® HP is suitable for use in commercial and industrial applications for roof pitches as low as 1 degree (1 in 50).

## METLOK® HP - ROOFING

BMT mm	Steel Base Mpa	Mass CB * kg/m <sup>2</sup>	Mass Zinc kg/m <sup>2</sup>	Min. Pitch°	Max Spans mm**	
					End	Internal
0.42	G550	4.68	4.61	1° (1 in 50)	1700	2100
0.48	G550	5.32	5.24	1° (1 in 50)	2200	2700

## METLOK® HP - WALLING

0.42	G550	4.68	4.61		1750	2100
0.48	G550	5.32	5.24		2200	2700

\*CB = Colorbond®

\*\* Max. Spans are based on N2 Wind Category and 1.5mm substrate

## CLIPS & FASTENERS

Metlok® HP sheeting is fixed to supports by Metlok® HP Dekclips. Always face side laps away from the prevailing weather.

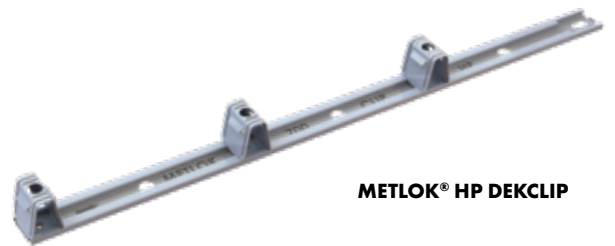

METLOK® HP DEKCLIP

### TIMBER SUPPORTS - HARD OR SOFT

**ROOFING & WALLING** #12 Hex Head Type 17 x 25mm. Add 10mm for softwood.

### STEEL SUPPORTS <1.5mm thick

**ROOFING & WALLING** #12 Hex Head Zip Screws x 25mm

### STEEL SUPPORTS >1.5mm thick

**ROOFING & WALLING** #12 Hex Head Self Drilling Screws x 25mm

**NOTE:** These fasteners do not make allowance for insulation blanket. In all cases it is important the screw head diameter does not exceed 11.5mm. Self drilling and tapping screws must comply with AS 3566.

## What is Met-TECH™?

Met-TECH™ is Metroll's Technical Resource Centre. It is the one stop shop for all of Metroll's product and technical information. Perfect for builders, contractors and specifiers to source all the information they may require. You can find other Met-TECH™ items on our website [www.metroll.com.au/resources](http://www.metroll.com.au/resources)

## SPRING CURVING

BMT mm	CONCAVE		CONVEX		
	Min. Radius	Max. Support Spacing	Min. Radius	Max. Support Spacing	Max. Radius for Drainage
0.42	90m	1200mm	90m	1200mm	220m
0.48	70m	1200mm	70m	1200mm	220m

## DRAINAGE & OVERFLOW

### Maximum Roof Run (m) for Slopes & Rainfall Intensity

Rainfall Intensity mm/hr	Metlok® HP Roof Slope					
	1 in 50 1°	1 in 30 2°	1 in 20 3°	1 in 12 5°	1 in 7.5 7.5°	1 in 6 10°
100	316	398	462	567	676	769
150	211	265	308	378	450	513
200	158	199	231	284	338	385
250	127	159	185	227	270	308
300	105	133	154	189	225	256
400	79	99	116	142	169	192

- Rainwater run-off and drainage capacity may place some limitations on the total length of a sheet run and must be considered during the design and construction phase of a project.
- The total length of roof sheeting; which shall include end laps, expansion joints or steps and draining the roof in one direction, shall be considered as a single roof run.
- Thermal expansion must also be considered.
- Maximum production and transport lengths may limit availability.

## LENGTH

Metroll supplies Metlok® HP cut to order as required; depending on load limit regulations set by local transport authorities. Lengths for manufacture need to be site measurements and not taken off plans. Sheet length is obtained by measuring the distance from the ridges to the external edges or fascia and adding a minimum of 50mm for overhang into the gutter.

To prevent damage when lifting long lengths, ensure sheets are lifted with the use of multiple lift point spreader bars.

## CLEAN UP

Prior to departing the work site remove all foreign debris, screws, rivets and especially any swarf created by drilling or cutting from the roof surface and/or inside gutters. Failure to do so may result in premature corrosion.

## CUTTING

Cut sheets with a method and in a location so that damage is avoided to sheets and other building products. Material should be cut on the ground and not above other materials. Remove all swarf and debris from the work and installation area. Sheets may be cut using a power saw with a steel cutting blade, a power nibbler or with tin snips. Avoid using abrasive discs as these can cause edge and coating damage.

## MATERIAL COMPATIBILITY

Never use lead flashings with Metlok® HP sheeting made from COLORBOND® and ZINCALUME® steels. Avoid drainage from copper roofs onto COLORBOND®, ZINCALUME® or galvanised steel roofing or rainwater products. Lead, copper, bare metal and some chemically treated timbers are not compatible with Metlok® HP.

## ADVERSE CONDITIONS

Localised environmental conditions can impact the corrosive nature of a site which may impact on material choice. Conditions that may impact on material choice include; direction of prevailing winds, rainfall intensity, duration of exposure, temperature, shelter and areas not washed by rainfall. Contact your local Metroll branch if you intend to use Metlok® HP within 1 km of industrial, chemical, marine or corrosive environments.

## MATERIAL SPECIFICATION & SCOPE

All roofing and walling should be specified on drawings as Metlok® HP, manufactured by Metroll and installed in accordance with the manufacturers recommendations. Base sheet steel is G550 with specified finish.

## AVAILABILITY & DELIVERY

Metlok® HP is available from Metroll Melbourne and Sydney branches. Contact your local Metroll branch for lead times, colours and availability.

Ensuring suitable arrangements are made to assist the unloading of Metroll trucks will help supply material in good order. When lifting long lengths by crane please ensure the load is evenly spread. Where a crane cannot be made available it is the customers responsibility to provide sufficient labour to assist the driver in unloading.

## METLOK® HP FOOT TRAFFIC

BMT (mm)	Internal Span (mm)	End Span (mm)
0.42	2200	1800
0.48	2800	2200

### NOTE

- Foot traffic limits are based on AS/NZS 1170.1 for R2 - Other roofs.
- All traffic must use the designated foot traffic paths and, at all times, follow safe practices.

## WALKING ON METLOK® HP

When walking on Metlok® HP roof sheeting always wear flat rubber soled shoes and only walk in sheet pans or near supports. In some applications, such as carports or verandahs, the use of crawl boards are recommended to avoid damage during installation

## METLOK® HP OVERHANGS

The overhangs on Metlok® HP are limited to the values in the following table. Overhangs have a minimum length of 50mm. Stiffened overhangs incorporate an angle or gutter attached to the sheet end.

ROOFING		
BMT (mm)	Plain (mm)	Stiffened (mm)
0.42	150	450
0.48	200	500

WALLING		
0.42	200	450
0.48	250	500

- Plain overhangs are limited to 20% of the adjacent end span.
- Stiffened overhangs are limited to 33% of the adjacent end span.

## TOLERANCES

Consideration should be given to the following manufacturing tolerances:

**Length** +0mm or -15mm **Width** +4mm or -4mm

## THERMAL EXPANSION

Change in temperature will cause all metals to expand and contract. There is minimal effect with steel roofing and walling, however care must be taken when long sheet runs are used and high temperature variations occur.

## MAINTENANCE

Exterior surfaces not washed by rainfall should be washed on a regular basis.

## CYCLONIC AREAS

The information contained in this publication is suitable for non-cyclonic areas only.

## CARE, HANDLING & STORAGE

Care should be taken at all times when handling sheets to preserve the quality of the finish. Keep packs dry, stored clear of the ground and protected from rain and moisture. Any sheets which become wet should be separated, wiped and placed in the open air to dry.

## STOP ENDS & LIPS - PITCH BELOW 15°

Turn the pans at the top of the sheets up 90° using a turn-up tool to prevent wind driven water entry.

Turn the pans at the bottom of the sheets down 30° using a turn-down tool to prevent water running back along the underside of the sheet.

## ROOF PITCH & FLASHINGS

For roofs with continuous sheets and the minimum roof pitch is 1° (1 in 50). This minimum pitch must be adhered to and all points of the roof to prevent ponding. Allow a minimum of 50mm for projection into gutters.

Flashings must be of a compatible material and 150mm minimum cover.

## OIL CANNING

Oil canning appears as waviness or rippling in the flat areas of metal panels. It is a characteristic of light gauge cold rolled metal roofing and cladding products. It can occur on all types of metal sheeting and is not considered a defect. Oil canning is a cosmetic issue and does not affect the structural integrity of the product. Oil canning may occur due to installation methods, thermal expansion and contraction and material colour. For more information please refer to the Oil Canning Data Sheet on our website.

## REFERENCED AUSTRALIAN STANDARDS

AS/NZS 1170.2	SAA Loading Codes - Wind Loads
AS 1397	Sheet & Strip Hot-Dipped Zinc Coated or Aluminium/Zinc Coated
AS 1526	One Part Polysulphide-based Sealing Compounds for the Building Industry
AS 1562.1	Design & Installation of Sheet & Wall Cladding, Part 1: Metal
AS/NZS 2179	Specifications for Rainwater Goods, Accessories & Fasteners - Metal Shape or Sheet Rainwater Goods and Metal Accessories and Fasteners
AS/NZS 2728	Prefinished/Prepainted Sheet Metal Products for Interior/Exterior Building Applications - Performance Requirements
AS 3566	Self-drilling Screws for the Building & Construction Industries

# 0.42mm & 0.48mm METLOK® HP LIMIT STATE CAPACITY TABLES

Tables and values must be used in conjunction with the Design Notes to Limit State Capacity Tables.  
Tables based on product testing on the James Cook University Airbox.

## 0.42mm METLOK® HP WITH 3 FASTENERS/SHEET/BATTEN

LIMIT STATE	SPAN TYPE	SUPPORT THICKNESS (mm)	PRESSURE (kPa) FOR SPAN (mm)				
			900	1200	1500	1800	2100
SERVICEABILITY	Internal	All	2.95	2.63	2.31	2.04	1.77
	End	All	2.91	2.58	2.36	1.98	1.55
STRENGTH	Internal	1.50+	2.79	2.58	2.36	2.23	2.10
		1.20	2.79	2.58	2.36	2.23	2.10
		1.00	2.79	2.58	2.36	2.23	2.10
		0.75	2.79	2.58	2.36	2.23	2.10
		0.55	2.79	2.58	2.14	1.79	1.53
		0.48	2.79	2.32	1.86	1.55	1.33
	End	1.50+	2.62	2.36	2.20	2.04	1.87
		1.20	2.62	2.36	2.20	2.04	1.87
		1.00	2.62	2.36	2.20	2.04	1.87
		0.75	2.62	2.36	2.20	2.04	1.87
		0.55	2.62	2.36	1.95	1.62	1.39
		0.48	2.62	2.11	1.69	1.41	1.21

## 0.48mm METLOK® HP WITH 3 FASTENERS/SHEET/BATTEN

LIMIT STATE	SPAN TYPE	SUPPORT THICKNESS (mm)	PRESSURE (kPa) FOR SPAN (mm)						
			900	1200	1500	1800	2100	2400	2700
SERVICEABILITY	Internal	All	3.25	2.90	2.56	2.23	2.07	1.91	1.74
	End	All	3.25	2.86	2.36	1.95	1.67	1.35	1.28
STRENGTH	Internal	1.50+	4.45	4.06	3.66	3.37	3.07	2.72	2.51
		1.20	4.45	4.06	3.66	3.33	2.86	2.50	2.22
		1.00	4.45	4.06	3.66	3.10	2.65	2.32	2.06
		0.75	4.45	3.93	3.14	2.62	2.25	1.96	1.75
		0.55	3.57	2.68	2.14	1.79	1.53	1.34	1.19
		0.48	3.10	2.32	1.86	1.55	1.33	1.16	1.03
	End	1.50+	4.02	3.66	3.31	2.95	2.51	2.29	2.05
		1.20	4.02	3.66	3.31	2.95	2.51	2.27	2.02
		1.00	4.02	3.66	3.31	2.81	2.41	2.11	1.88
		0.75	4.02	3.57	2.86	2.38	2.04	1.79	1.59
		0.55	3.25	2.44	1.95	1.62	1.39	1.22	1.08
		0.48	2.81	2.11	1.69	1.41	1.21	1.06	0.94

### DESIGN NOTES

- For timber battens/purlins, use 1.50+ support thickness values.
- Type 17 screws must penetrate more than 25mm into hardwood or 35mm into softwood.
- Metal supports are produced from hi-tensile steel.
- For most economic results use longer internal spans than end spans (in a ratio of 10:8).
- Equal span systems must be designed using end span values.

# 0.42mm & 0.48mm METLOK® HP SPAN CHART

Tables and values must be used in conjunction with the Design Notes to Limit State Capacity Tables.  
Tables based on product testing on the James Cook University Airbox.

## 0.42mm METLOK® HP

FASTENER FREQUENCY	SPAN TYPE	SUPPORT THICKNESS (mm)	ROOF SPANS (mm) FOR WIND CATEGORY						WALL SPANS (mm) FOR WIND CATEGORY					
			N1	N2	N3	N4	N5	N6	N1	N2	N3	N4	N5	N6
3+ clips per sheet	Internal	1.50+	2100	2100	1000				2100	2100	2100			
		1.20	2100	2100	1000				2100	2100	2100			
		1.00	2100	2100	1000				2100	2100	2100			
		0.75	2100	2100	1000				2100	2100	2100			
		0.55	2100	1950	1000				2100	2100	1650			
		0.48	2100	1700	1000				2100	2100	1450			
	End	1.50+	1750	1700					1800	1750	1650			
		1.20	1750	1700					1800	1750	1650			
		1.00	1750	1700					1800	1750	1650			
		0.75	1750	1700					1800	1750	1650			
		0.55	1750	1550					1800	1750	1350			
		0.48	1750	1350					1800	1750	1150			

## 0.48mm METLOK® HP

FASTENER FREQUENCY	SPAN TYPE	SUPPORT THICKNESS (mm)	ROOF SPANS (mm) FOR WIND CATEGORY						WALL SPANS (mm) FOR WIND CATEGORY					
			N1	N2	N3	N4	N5	N6	N1	N2	N3	N4	N5	N6
3+ clips per sheet	Internal	1.50+	2700	2700	2400	1200			2700	2700	2700	2150	900	
		1.20	2700	2700	2200	1200			2700	2700	2700	1950	900	
		1.00	2700	2700	2050	1200			2700	2700	2700	1850	900	
		0.75	2700	2700	1700	1150			2700	2700	2300	1550	900	
		0.55	2700	1950	1250				2700	2600	1650	1100		
		0.48	2400	1700	1100				2700	2300	1450	950		
	End	1.50+	2200	2200	1900	950			2250	2200	2200	1700		
		1.20	2200	2200	1750	950			2250	2200	2200	1550		
		1.00	2200	2200	1650	950			2250	2200	2150	1450		
		0.75	2200	2150	1350	900			2250	2200	1850	1250		
		0.55	2150	1550	1000				2250	2100	1350	900		
		0.48	1900	1350					2250	1800	1150			

### DESIGN NOTES

- Spans shown reflect the minimum value of the Serviceability, Strength and Foot Traffic tables.
- The Wind Category is based on AS 4055 and results include an allowance for local pressure factors.
- If roof pitch is less than 10 degrees, then increase the Wind Category upwards by 1, and apply to an area not less than 1.2m from all corners.
- For timber battens/purlins use 1.5+ support thickness values.
- Metal supports are produced from hi-tensile steel.
- For most economic results use longer internal spans than end spans (in a ratio of 10:8).
- Equal span systems must be designed using end span values.

# METLOK® HP INSTALLATION

## BEFORE COMMENCING INSTALLATION

Ensure cladding support is in the same plane. Ensure sheet overhang does not exceed recommendations. Check roof pitch is within minimum recommendations. For maximum hold, check first and last supports and clips are at least 75mm from the end of the sheet. Ensure set out is correct to avoid complicated post-install rectification. Installation is quicker if all clips are installed before the sheeting.

## SHEET PLACEMENT PRIOR TO INSTALL

Determine prevailing wind and weather direction for maximum weather tightness. Identify downward direction and start install from that end.

Turn sheets on the ground rather than on the roof, this is easier and safer. Before lifting ensure sheets are the correct way up and the overlapping side is facing the edge of the roof where installation will commence. Position sheet bundles over firm supports, not at mid span of roof members.

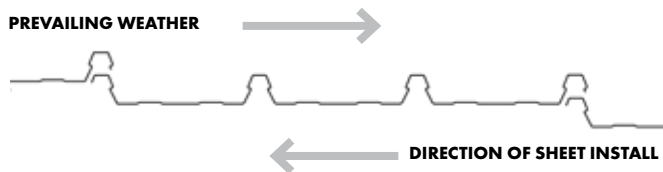

## INSTALLATION STEPS

1. Install safety wire and insulation as per manufacturers recommendations.
2. Position the first Metlok clip by fixing to the support member nearest the roof edge.

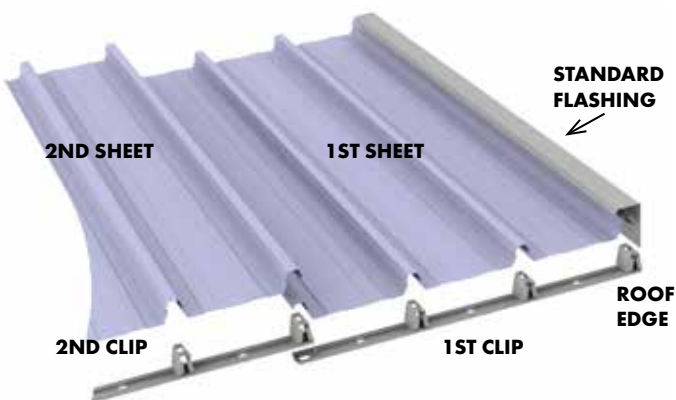

3. Fix the clip as indicated. Ensure the clip is 90° to the edge of the sheet and facing the direction required for laying.

4. Using a string line align the clips using the first sheet as a straight edge. Fix a clip to each support member working towards the high end of the roof.



5. In accordance with the manufacturers recommendations, fix the Hex-head fasteners through the top of the clip into the support member.



6. Continue to work along the roof edge ensuring correct alignment at its ends relative to the gutter and ridge, (parapet or transverse wall).
7. After all of the initial first clips have been installed, attach the second clip row to each purlin. If desired, all clips can be attached to the purlins at this stage.
8. Measure the distance from the gutter end of the sheet to the support.
9. The first sheet must be placed square to adjacent edges. Position the first sheet so it overhangs the desired amount (normally 50mm) into the gutter.

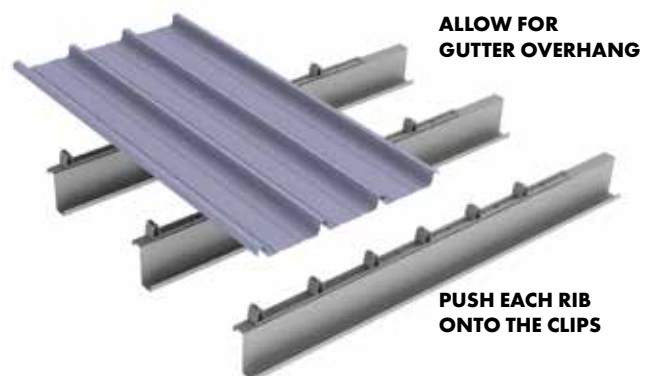

10. The order in which the ribs are snapped into place is important. Start with Rib 2, then the adjacent Rib 3 and move to the next purlin and repeat.



- Once all second and third ribs have been snapped into place, secure the overlap by walking along the edge and gently engaging the overlap. Ensure the overlap is fully engaged for the entire sheet length before placing the next sheet.



- Continue to lay at least two rows of clips in advance of the laid sheets to all of the support members

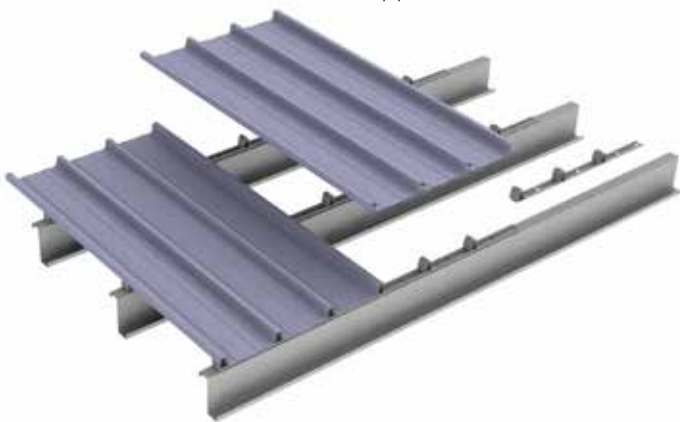

- Position the next sheet taking care to ensure it positively engages the full length of the edge of the preceding sheet.
- Engage all clips and sheets as per Steps 10 - 13.
- If the final space is less than a full sheet width, the sheet can be cut and clips shortened as required.

#### **VIC BALLARAT**

**P: 03 5335 6416 E: ballarat@metroll.com.au**  
20 Wiltshire Lane, Ballarat, VIC 3356

#### **GEELONG**

**P: 03 5248 2005 E: sales@geelong.metroll.com.au**  
55 Wills Crescent, Moolap, Geelong, VIC 3224

#### **LAVERTON**

**P: 03 8369 8300 E: orders@laverton.metroll.com.au**  
100 -102 William Angliss Drive, Laverton North, VIC 3026

#### **PAKENHAM**

**P: 03 8710 9300 E: sales@pakenham.metroll.com.au**  
14 - 24 Peet Street, Pakenham, VIC 3810

#### **SUNSHINE P: 03 9480 3744**

**E: sales@sunshine.metroll.com.au**  
329 St Albans Road, Sunshine, VIC 3020

## **ALIGNMENT CHECK DURING INSTALL**

From time to time check that sheets continue to be parallel with the first sheet. This is done by taking two measurements across the width of one fixed sheet. Approximately half way through the job, perform a similar check from the finishing line.

## **INSTALLATION FOR WALL APPLICATIONS**

The procedure for walls is similar to roof installation. Sheets can be prevented from sliding downwards by pierce fixing through each sheet beneath the flashing or canopy along the top of the sheets.

## **POTENTIAL DISTORTION**

Metlok® HP is a concealed fix roofing profile that is secured by fixing clips attached to the building substrate. The roof sheet is snapped into place over the clips. In some instances slight bulging or distortion may be seen around the fixing clips caused by slight misalignment of the structure or sheet during installation. This poses no issue to the structural integrity of the cladding and will not affect the longevity of, or the warranty for the BlueScope Steel material. To reduce distortion, always follow the recommended installation procedure, use care and attention and do not force the material into place.

## **INSTALL OF COMPATIBLE TRANSLUCENT SHEETS**

Translucent sheeting experiences greater thermal expansion. As a consequence cladding should be fixed using oversized holes and sealing washers. Refer to fastener manufacturer for detail. When translucent sheeting is used in conjunction with concealed fixed cladding, ensure the fasteners do not penetrate the steel cladding. Do not exceed maximum span/ support distances specified by the translucent sheeting manufacturer.

#### **NSW ALBURY**

**P: 02 6043 6800 E: sales@albury.metroll.com.au**  
12 Terry Court, Thurgoona, NSW 2640

#### **WAGGA WAGGA**

**P: 02 5924 4500 E: sales@wagga.metroll.com.au**  
11 Saxon Street, Wagga Wagga, NSW 2650



**metroll.com.au**